

TO-8 Test Mount PN: TO8-1000-2A

The TO8-1000-2A is an ideal mount for the operation of Photodigm's TO-8 packaged lasers. Laser is held in-place with aluminum clamp plate and two screws. Threaded holes are supplied on all sides of the housing for single post mounting to an optical bench. Interface cables are not supplied.

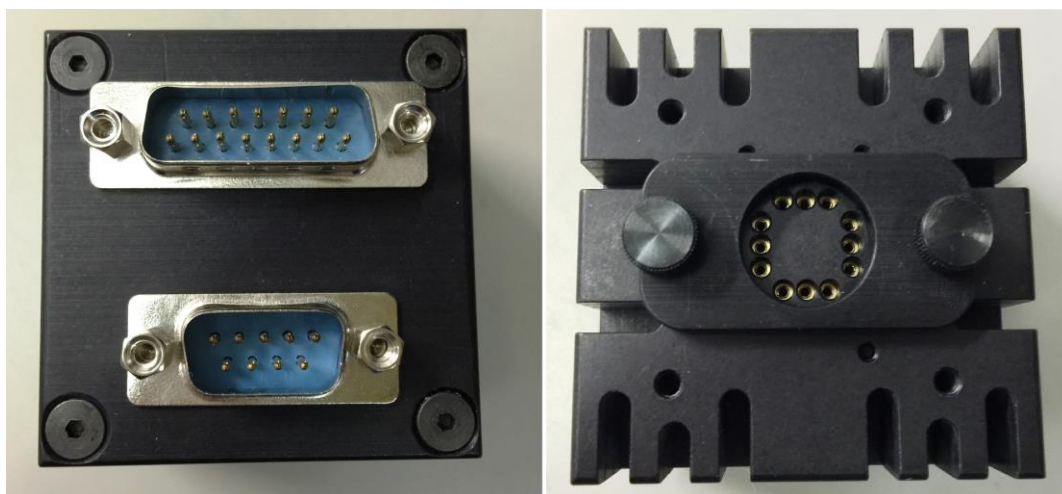

1. 15-Pin D-Sub for Thermistor and TEC
2. 9-Pin D-Sub for Laser and Photodiode
3. Dimensions are 2" x 2" x 1.25"
4. 4-40 holes provided for 30mm cage system on front face

Pin#	Device	Signal	D Connector
1	TEC	Pos +	D15 Pin 1
2	Laser	Anode	D9 Pin 8&9
3	Thermistor	Bottom	D15 Pin 7
4	Thermistor	Top	D15 Pin 8
5	Photodiode	Cathode	D9 Pin 1
6	Photodiode	Anode	D9 Pin 6
7	—	Unused	—
8	Laser	Cathode	D9 Pin 4&5
9	TEC	Neg -	D15 Pin 3
10-12	—	Unused	—

Typical test setup

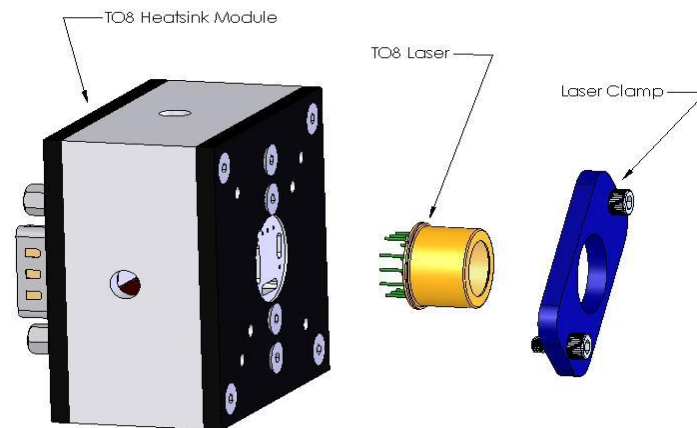

*Laser plugs into heatsink module

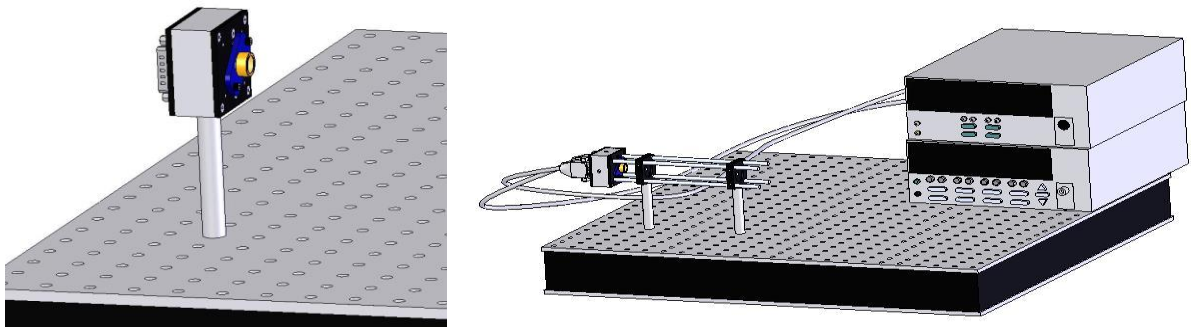

The heat sink module can be mounted on a single post using ¼-20" threaded holes on all 4 sides 90 degrees apart.

*Laser Not Included in Assembly.