

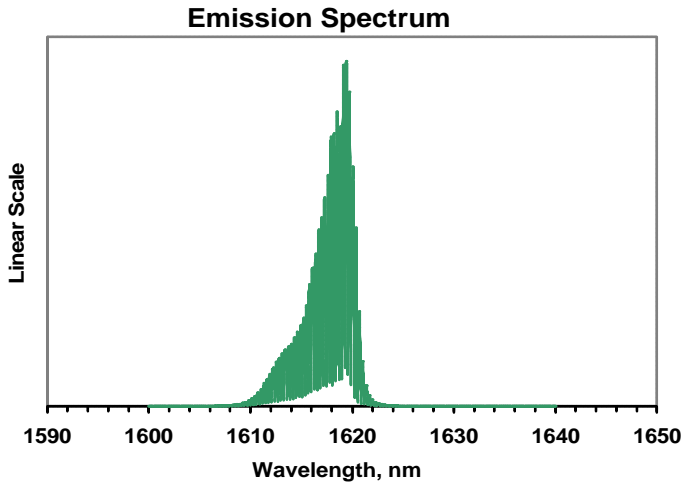

MODEL	QFLD-1620-2S
PART NUMBER	SAMPLE

Parameter	Value	Units
Internal Temperature	25	°C
Thermistor Resistance	10.0	k?
Optical Output Power	2	mW
Threshold Current	40	mA
Operating Current	125	mA
Operating Voltage	1.09	V
Monitor Current	0.04	mA
Monitor Dark Current	0	nA
Center Wavelength	1618	nm
Spectral Width	4.59	nm

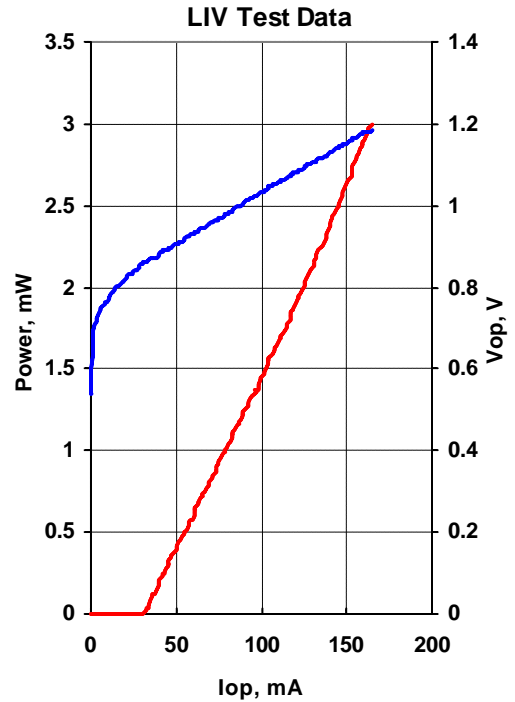

Fiber Type	SMF-28
NA	0.13
Connector	FC/PC

Pin	Connection
1	TE Cooler (+)
5	LD Anode (+)
7	PD Cathode (+)
8	PD Anode (-)
9	LD Cathode (-)
11	Thermistor
12	Thermistor
14	TE Cooler (-)

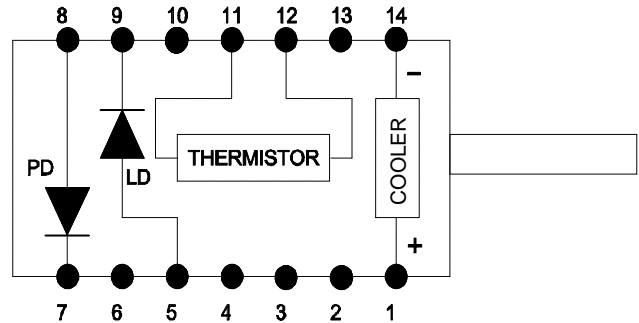

Operator	
Date	