

# PV Oven Series

version 2.0/2015

The **Covesion PV Oven Series** is specially designed to provide secure mounting and robust thermal stability for our PPLN crystals.



## Key Features

- Compact and simple to use
- Fully insulated construction using a high performance plastic material
  - Low external temperature
  - Minimal air currents
- Auto-locating dowel pins allow crystals to be exchanged with minimal realignment.
- High temperature stability of  $\pm 0.01^\circ\text{C}$  when used with OC2 Temperature Controller
- Various mounting options available, compatible with a range of opto-mechanical systems

Covesion's team of optical engineers have designed a range of PPLN crystal clips, ovens, temperature controllers and mounting accessories, providing a **complete PPLN system** for easy integration into your optical arrangement.

Our PPLN clips are easily mounted into the oven using the auto-locating pins. These also allow the PPLN clips to be swapped in and out with minimal realignment of the optical train.

Finely sprung pins in the oven lid hold the PPLN crystal clip securely in place. The oven and PPLN crystal can then be mounted in any orientation, flexible to your choice of optical arrangement.

Covesion recommends the **OC2 temperature controller** for high thermal stability of  $\pm 0.01^\circ\text{C}$ . This long term stability can be maintained at any temperature between near-ambient and  $200^\circ\text{C}$ .



Product Code	Crystal Length (Max Suitable) mm	Oven Length, L mm	Recommended Products		
			PPLN Clip Kit	Mounting Adapters	Temperature Controller
PV10	10	22	PC10	PVP1 †, PVP1R ‡	OC2 * High stability ( $\pm 0.01^\circ\text{C}$ ) temperature controller
PV20	20	32	PC20	PVP2 †, PVP2R ‡	
PV40	40	52	PC40	PVP2 †, PVP2R ‡	

\* Also compatible with the OC1 which has been superseded by the OC2. For customers who have previously purchased ovens with a 6-pin plug, we offer an adapter lead for use with the OC1 and OC2.

† Post-mounting adapter plate with standard M4 thread.

‡ Flexure stage adapter.

# PV Oven Series

version 2.0/2015

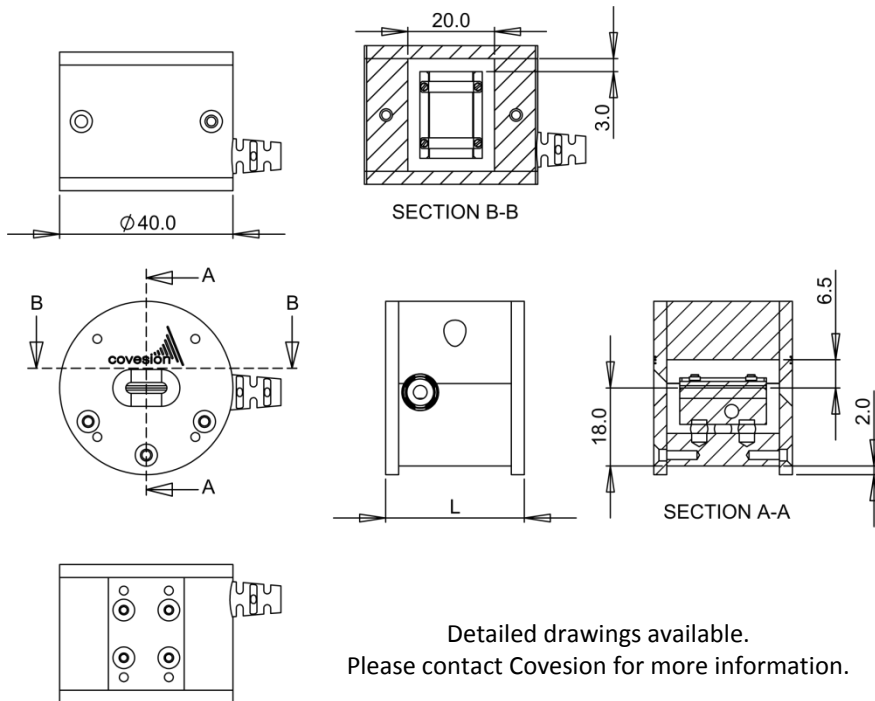

Detailed drawings available.  
Please contact Covesion for more information.

Pin Configuration	
1	Heater
2	Oven detect
3	Sensor
4	N/C
5	Oven detect
6	N/C
7	Heater
8	Sensor

Cable plug type: Lumberg SV80

Cable length: ~1.2m

Temperature sensor: PT100

Heating method: Resistive heater

Specifications	
Maximum crystal thickness <sup>1</sup>	1.0mm
Temperature stability <sup>2</sup>	±0.01°C
Maximum operating temperature (continuous)	210°C
Optical height <sup>3</sup>	18mm
Aperture slot size (W x H)	7 x 2.5mm
Operating voltage (power)	12V (3.6W)
	18V (8.3W)
	24V (15W)

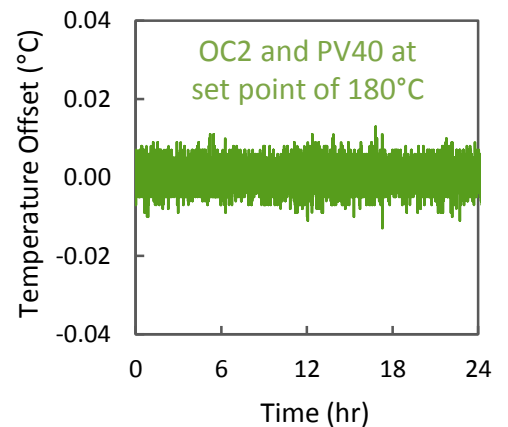

1. When used with PC clip kit, including 1mm thick ITO-coated glass.
2. When used with the OC2 controller from 5°C above ambient to 200°C.
3. Assuming a 0.5mm PPLN crystal and measured from screw-mounted base to aperture centre.

**Accessories available:** PC clip kits, mounting adapters, OC2 temperature controller and adapter leads.

# Kokyo

株式会社 光響

Email : [info@symphotony.com](mailto:info@symphotony.com)

Web : <https://www.symphotony.com/>

Covesion Ltd. Unit A7, The Premier Centre, Premier Way, Romsey, SO51 9DG, UK

Registered in England No. 06338847, VAT No. 943 1896 00

Copyright © 2015 Covesion Ltd.