

Model: PUMA-665-2

SAMPLE DATASHEET

Output Power (from fiber):

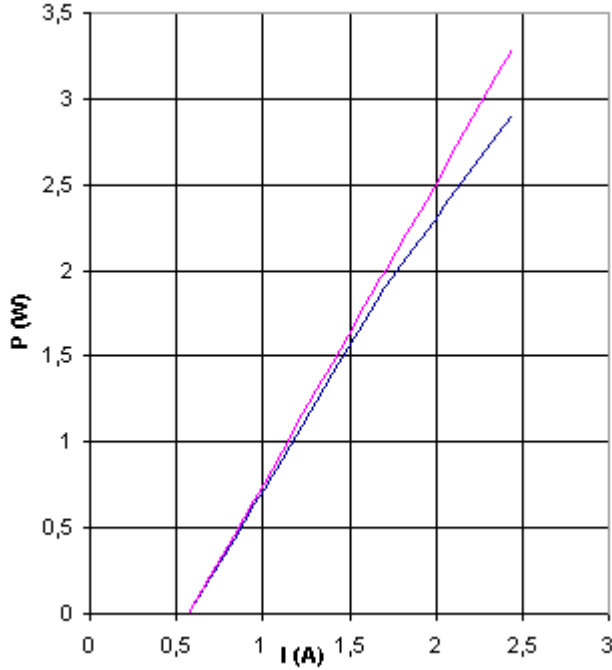

Optical characteristics:

Output optical Power (Pmax)	2.8W
Wavelength	667nm
Case temperature	18°C

General characteristics:

LDcurrent (Imax)	2.4A
Power supply voltage	10-12V
Feedback resistance (Rfb)	98mOhm
Electrical Power	25W
Temperature Range	10-20°C
Aiming lens	optional

Fiber output characteristics:

Fiber core diameter (Dfib)	200µm
Numerical Aperture (NA)	0.22
Optical connector	FC/PC

Emission Spectrum:

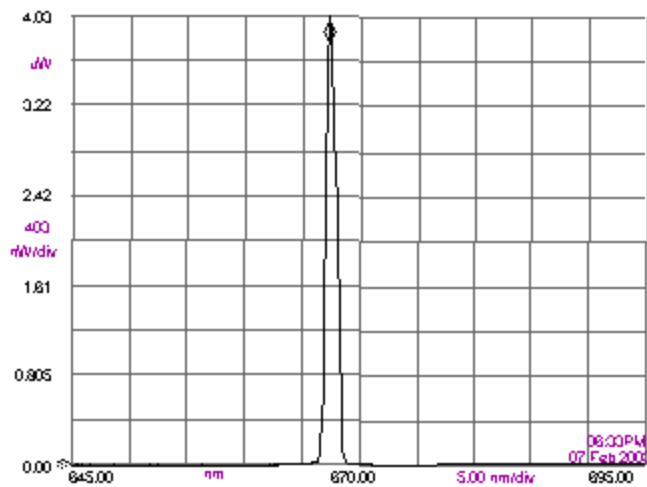

Mechanical Dimensions:

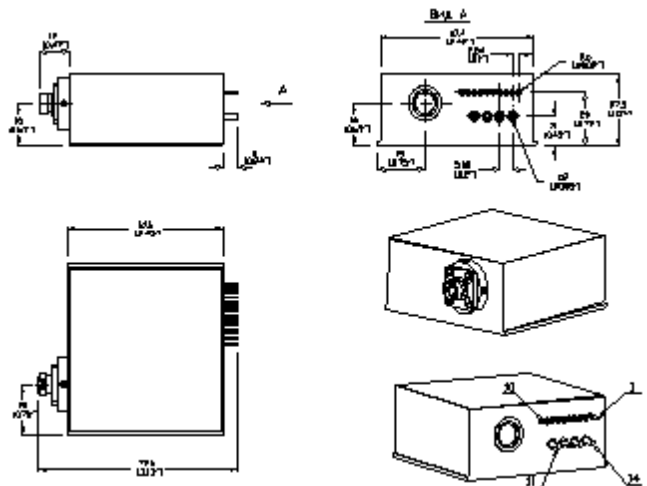



Fiber Coupled Laser Diode Module PUMA

Operating Instructions

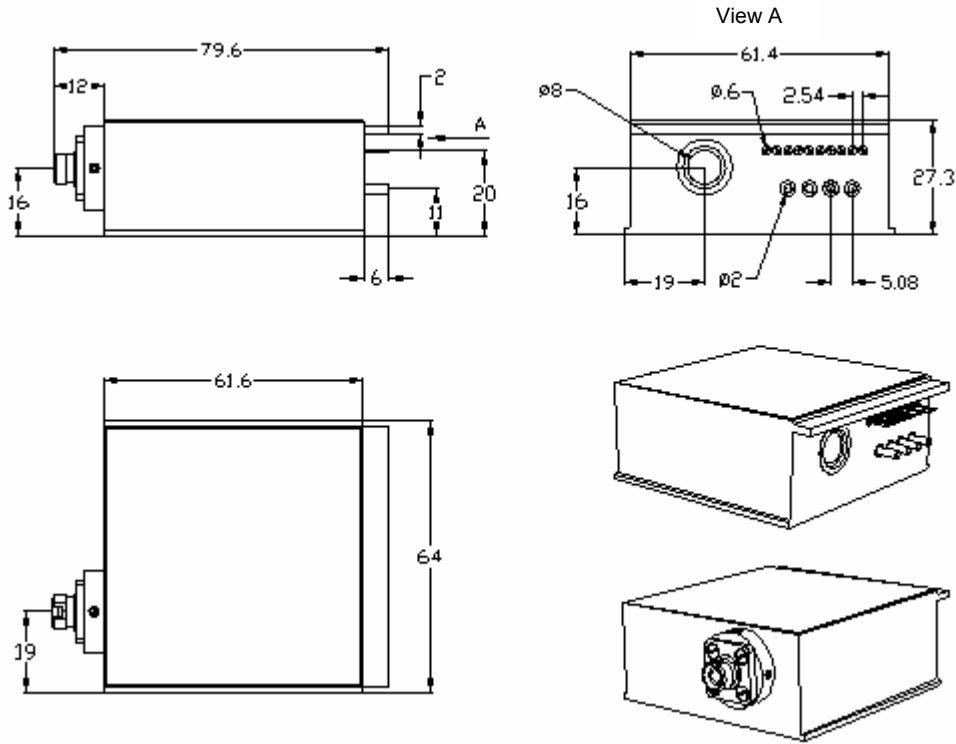

Fig. 1 Mechanical dimensions of PUMA module

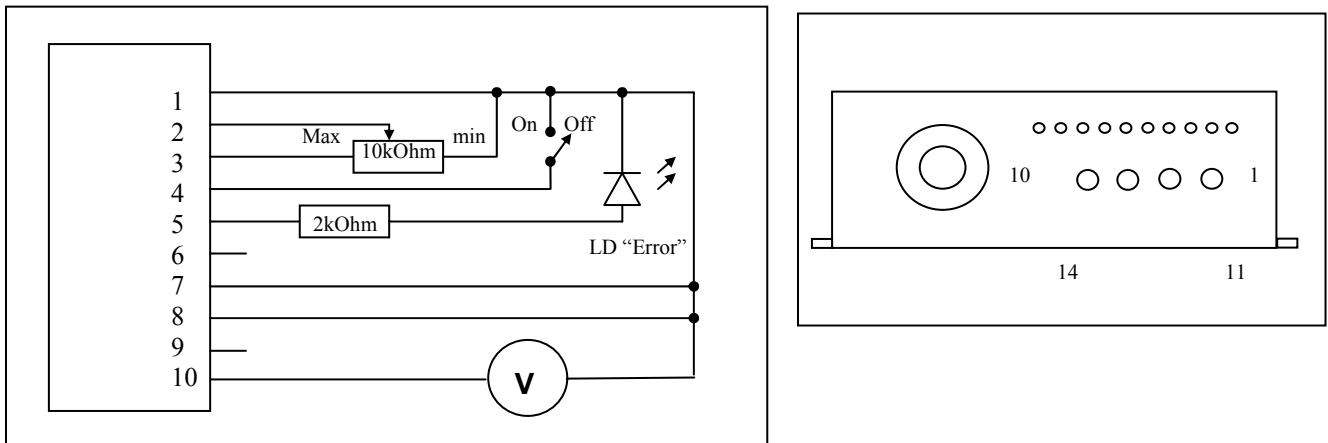

Fig. 2 Circuit diagram and pin location

Pin Assignment

Pin	Symbol	Type	Description
1	V_L	Input	Digital control of the LDs by current
2	V_A	Input	Analog control of the LDs by current
3	REF	Output	Reference voltage 5V/2mA max
4	STB	Input	Switch on/off LDs
5	ERROR	Output	Signal of the error
6	RE	Input	The permission of the automatic error of the trigger off
7	Gnd		Common (analog signal)
8	Gnd		Common (analog signal)
9	-	-	-
10	CON	Output	Signal that is proportional to the current of LDs
11			(+) Power supply
12			Common (power supply and digital signal)
13			Common (power supply and digital signal)
14			(+) Power supply

V_L Input:

This is a digital input. Logic 0 corresponds to a voltage between 0V and 0.8V while logic 1 corresponds to a voltage between 4V and 5V. In the formula for I_{LD} (see below), values of $V_L = 0$, or $V_L = 1$ should be substituted. When Pin1 and Pin3 are connected, $V_L = 1$. When Pin1 and Pin7 (or Pin8) are connected, $V_L = 0$. It is possible to use the V_L input for a smooth control of LD current. For this purpose, it is necessary to apply a signal from a digital generator (alternating logic 0 and logic 1) with frequency between 2 kHz and 10 kHz to Pin1. In this case, V_L is equal to the ratio of pulse duration and period.

REF Output:

This is a "Reference" voltage output. The maximal current in this line is 2mA. It can be used only in the formation of control voltage V_A (see the Circuit Diagram above). For this purpose, it is recommended to use a variable resistor not less than 3kOhm.

ERROR Output:

When ERROR=1 (voltage 4- 5V), the laser is locked and it is impossible to turn it on. When ERROR = 0 (voltage 0-0.8V) the laser is unlocked and operating according to the values of V_A , V_L , and STB inputs. The maximum current in the ERROR line is 2mA. The condition ERROR=1 arises in the following cases: when turning on the power, when the laser module is overheated, and when the power supply voltage is too low.

RE Input:

In order to turn the laser ON apply logic 1 (4- 5V) to Pin6. Then the error condition (ERROR=1) will automatically change to the error-free condition (ERROR=0), provided there are no other reasons for ERROR=1. When logic 0 (0-0.8V) is applied to Pin6, the condition ERROR=1 will be kept indefinitely. (This feature may be convenient when it is desirable to turn on the laser and leave it unattended. If overheating takes place, the laser will be switched off and will not be turned on automatically even when the temperature is restored).

CON Output:

For measuring of this voltage (proportional to the LD current) use a voltmeter with independent power supply (batteries). Connect it between Pin10 (CON) and Pin7 or Pin8. Minimum voltage is 0V (Current=0). Maximum voltage is approximately 0.2V (Maximum current). Laser current can be calculated with the formula $I_{LD} = V_{CON} * R$. Each laser head has its own value of R (0.07-0.11 Ohm).

Laser diode current control

LD current is controlled by values of V_A , V_L , and STB.

Signal STB is used to turn the LDs on and off (logic 1 corresponds to LD “OFF”; logic 0 corresponds to LD “ON”). Current of the LDs (I_{LD}) is given by

$$I_{LD} = V_A/5V \times (1 - V_L) \times I_{max}$$

Where,

V_A is analog voltage at Pin2 (0-5V)

V_L digital signal at Pin 1(see above);

I_{max} maximum current of the LD.

Current of the LD can be controlled by both analog signal V_A (in this case V_L should be 0) and digital signal V_L (in this case V_A should be 5V), or by means of both signals.

Adjustments in voltages V_A and V_L alter the value of the current with the time delay within 10ms. When using STB Input, the time delay for switching the LDs “ON” is less than 0.1ms and the time delay for switching the LDs “OFF” is not more than 0.01ms.

Cooling system

An air-cooled radiator is required for heat dissipation from laser module PUMA. The thermal resistance of the radiator must be less than 0.12°C/W. It is extremely important to have a smooth high quality radiator surface under the laser module. The deviation from flatness must be less than 0.05mm. It is necessary to apply a thermo-conductive film or paste between the laser module and the radiator surface. Thermo-conductive paste must be uniformly distributed over the bottom surface of the module. It is desirable to minimize the thickness of thermo-conductive film. This can be done by gently rubbing and pressing the module and the radiator against each other with the paste between them.

Optional built-in TEC and temperature controller

Laser module PUMA with optical power up to 10W may be equipped with optional built-in TEC, thermistor, and temperature controller. In this option, operating temperature of laser diodes (t_{stab}) is set at the factory (typically at 25°C). The temperature controller is locked at that set point with tolerance $\pm 1^\circ\text{C}$. Switching PUMA “ON” and “OFF” may alter the tolerance to $+3/-1$ degree C. Note that LD temperature set point (t_{stab}) can be adjusted through pin 9.

If during operation temperature of laser diodes rises more than 5°C above the set point (t_{stab}), the laser current will be automatically switched “OFF”, and value “ERROR=1” will appear at the ERROR Output. This may happen due to inadequate heat removal through a radiator or heat sink.

Temperature control (pin 9)

Pin 9 can be used for changing temperature set point t_{stab} in the following way. If pin 9 is disconnected, t_{stab} is equal to the set point programmed at the factory (typically 25°C). When resistor R_{add} is connected between pin 9 and pin 3 (REF), see circuit diagram in Fig.3, t_{stab} will be increased according to calibration table below. When resistor R_{add} is connected between pin 9 and pin 7 (Gnd), see Fig.4, t_{stab} will be decreased as shown in the table.

Value of resistor R_{add} between pin 9 and pin 3 (REF)	Increase in temperature setpoint t_{stab} , degrees C
100k	+2
51k	+4
33k	+6
24k	+8
18k	+10

Value of resistor R_{add} between pin 9 and pin 7 (Ga)	Decrease in temperature setpoint t_{stab} , degrees C
110k	-2
56k	-4
39k	-6
30k	-8
24k	-10

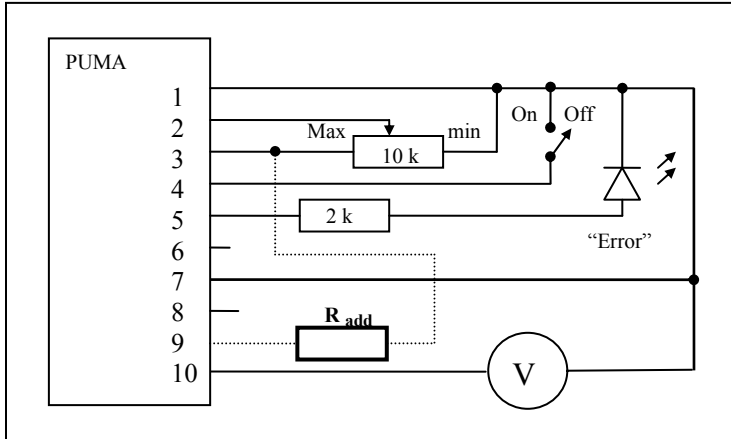

Fig. 3

Circuit diagram with R_{add} connection for increasing the temperature set point in PUMA module.

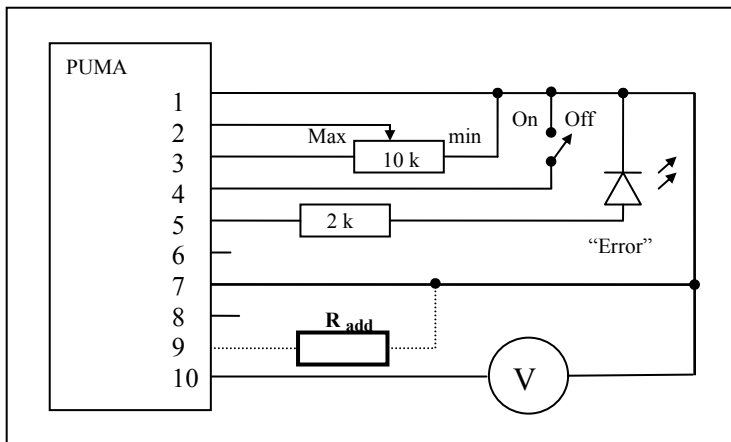

Fig. 4

Circuit diagram with R_{add} connection for decreasing temperature set point in PUMA module.

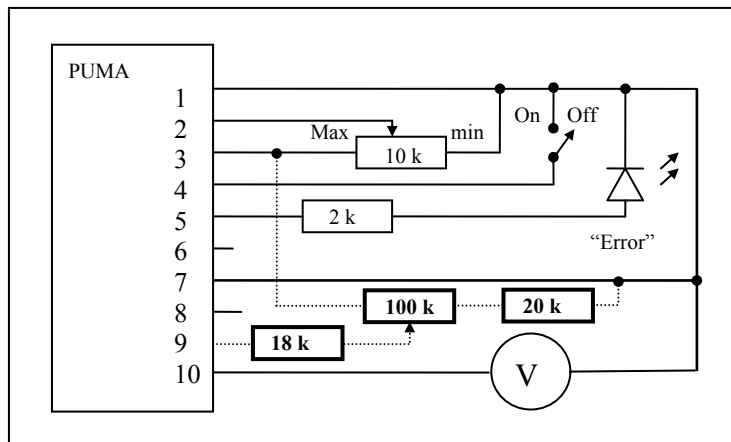

Fig. 5

Circuit diagram with R_{add} connection for changing temperature set point from +20°C to +35°C in PUMA module.

Optical cable

Type of connector: FC/PC. Type of fiber: fused silica/fused silica with fiber diameter of 100µm or more and numerical aperture of 0.22 or more.

Power supply

A stabilized constant-current power supply should be used with the laser module. Voltage of 14.5±0.5V is required for laser operation at all wavelengths. Maximum current is not more than 6A.

Testing

The following electrical circuit is recommended for testing of the laser module. It contains a variable resistor for the LD current control, an On/Off switch, a LED indicator for error signal, and a voltmeter for measurements of voltage that is proportional to the LD current.

Turning the laser module "ON"

Turn "ON" the power supply unit. The LED "ERROR" will be "ON" for 5–30 seconds, until the LD temperature is stabilized. During this time the LD power will be locked at 0.

After the LD temperature is stabilized and the LED "ERROR" turns "OFF", a desired LD power can be set with the variable resistor. The maximum operational temperature of the laser module is 45°C. If the external cooling is inadequate and the module temperature reaches 45°C, the power of LDs will be turned "OFF" automatically.

Turning the laser module "OFF"

Turn "OFF" the power supply unit. The variable resistor may be left at any position. When the unit is turned "ON" next time, the same LD power will appear.

LD current control

All the LDs are connected together in series and same current carries through all of them. The voltage at the output "CON" is proportional to the current through LDs.

This voltage can be measured with a battery-powered voltmeter connected between outputs "Gnd" and "CON". The internal resistance of the voltmeter must be higher than 1MΩ. The current of LDs can be calculated according to the equation $I_{LD} = V_{con} / \Sigma R_x$. The value R_x is individual for each laser module.

