

976nm Wavelength Stabilized Laser Diode

By adopting specialized fiber-coupling techniques, the manufactured diode laser modules have a high efficiency, stability and superior beam quality. The modules are achieved by transforming the asymmetric radiation from the laser diode chip into an output fiber with small core diameter by using special micro optics. Inspection and burn-in procedures guarantee reliability, stability and long lifetime of each modules.

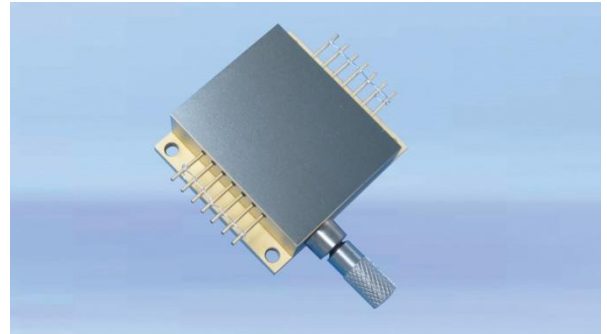

Features

- 14W output power
- 105µm, NA 0.22 fiber pigtail
- Wavelength stabilized

Applications

- Fiber laser pumping
- Scientific research

Package Dimension

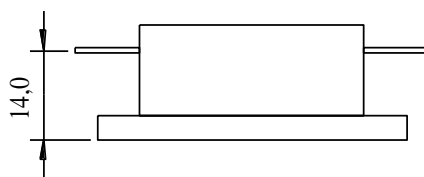

Pin	Function
1	LD +
2	PD (N)
3	PD (P)
4	Thermistor
5	Thermistor
6	NC
7	LD -
8	Red +
9	Red -
10	NC
11	NC
12	NC

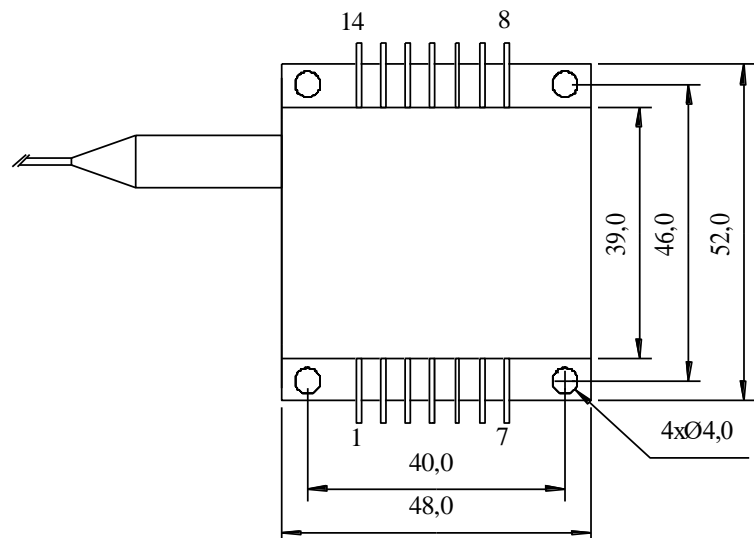
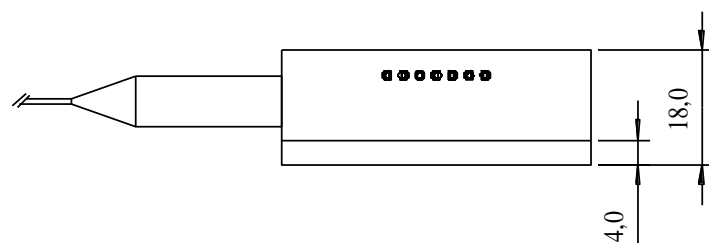

Module Specifications

Model	M976±0.5-14-F105/22-T6
Optical parameters	
Output power (W)	14
Central wavelength (nm)	976
Wavelength tolerance (nm)	± 0.5
Spectral width (90%, nm)	<0.5
Wavelength temp. coefficient (nm/°C)	0.02
Feedback protection 1030-1100nm (dB)	>40
Fiber parameters	
Fiber core diameter (µm)	105
Numerical aperture	0.22
Fiber pigtail length (m)	1
Electric parameters	
Threshold current (typical, A)	0.6
Operating current (typical, A)	9.0
Operating voltage (typical, V)	3.5
Slope efficiency (W/A)	1.6
Power conversion efficiency	42%
Other parameters	
Operating temperature (°C)	25 – 30
Storage temperature (°C)	-20 – +80
Soldering temperature (°C)	250 (10s)

- Notes: 1. Module specifications and dimension are subject to change without notice.
 2. ESD precautions must be taken.
 3. The minimum fiber bend diameter should be 300 times greater than the fiber core diameter.
 3. Reduced lifetime if improperly used or used above operating conditions.
 4. A non-condensing environment is required for storage and operation below the ambient dew point.

Compliance with Regulatory Requirements: This industrial laser is an OEM version of a diode laser. As such, it is intended only for integration into other equipment. This laser does not comply with IEC and CDRH requirements. The customer is responsible for IEC and CDRH certifications of the system that incorporates this industrial laser.

