



**Kokyo**  
株式会社光響

住所：京都市下京区烏丸通四条下ル水銀屋町637番地 第5長谷ビル2階  
Email : [info@symphotony.com](mailto:info@symphotony.com) TEL : 070 - 6925-5558  
Web : <https://www.symphotony.com/> FAX : 075 - 320 - 1604

# Directly Modulated Laser



Pilot Photonics offers FP and DFB lasers with a high modulation bandwidth above 15 GHz for applications that rely on high speed direct modulation. The DFB is also available in a high-power option with integrated SOA. The laser is packaged in a 7-pin butterfly package with RF (K) connector.

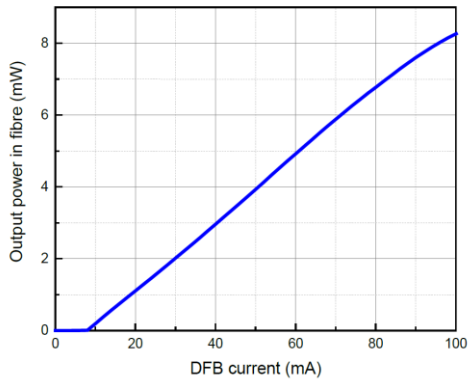

Typical P-I Curve

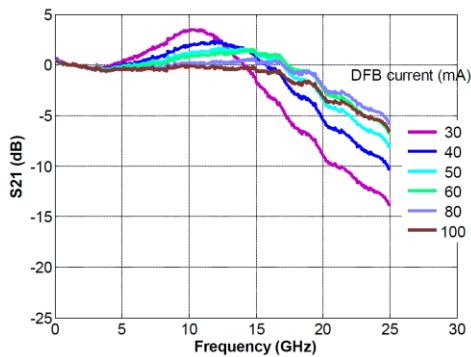

Typical S21 - Modulation Response Curves

## Typical Specifications

Wavelength	1525 - 1560 nm
Optical Power	8 mW (DFB, FP) 16mW (DFB+SOA)
Modulation Bandwidth (3 dB)	>15 GHz (FP), >20 GHz (DFB)
Operating Current	40 - 80 mA
Forward Voltage	2.6 V
Input Impedance Matching	50 Ω

## Features

- C-band wavelength
- Output power 8 mW (DFB, FP), 16 mW (DFB+SOA)
- High bandwidth > 15 GHz
- Fabry-Perot and distributed feedback lasers available
- Compact laser package with RF connector, built-in TEC, thermistor, and optical isolator
- Single mode or polarisation maintaining fibre coupled output

## Applications

- Direct modulation data transmission
- High speed optical communications
- Radio over fibre applications
- Laboratory testing and measurement

## Available in a Lyra driver module.

Each LYRA module consists of rugged metal housing containing a heat-sink and embedded control electronics. On the back panel it has 3 ports: DC power (12V nominally), USB for computer control, and REMOTE control. On the front panel there are two ports, an optical bulkhead adapter (FC-type) for connecting to optical fibre patch-cords, and an RF connector, through which the RF or data signal is applied.



## Directly Modulated Laser

Laser Specifications	Min.	Typ.	Max.	Unit	Notes
Centre Wavelength					
Fabry Perot		1570		nm	Gain peak wavelength for FP lasers
DFB	1526	1540	1558	nm	
DFB + SOA	1526	1545	1558	nm	
Centre Wavelength Tuning range	-1	-	+ 1	nm	Thermal tuning
Average Output Power					Fibre-coupled
Fabry Perot		6	8	mW	SOA bias at 30 mA
DFB		6	8	mW	
DFB + SOA		12	16	mW	
Side Mode Suppression Ratio (SMSR)	40	50	60	dB	Not Applicable for FP Lasers. SMSR can only be ensured if internal isolator is installed
Modulation bandwidth (3 dB)					At 60 mA bias current. 50 $\Omega$ input matching
Fabry Perot		15	17	GHz	
DFB		20	22	GHz	
DFB + SOA		17	20	GHz	
Operating laser temperature	+15		+45	$^{\circ}$ C	
Laser drive current	0	50	80	mA	Use high quality and low noise current and voltage sources
Laser threshold current					
Fabry Perot		10		mA	
DFB		12		mA	
DFB + SOA		12		mA	
Laser bias voltage		2.6	3.3	V	
RF Input power	-	-	28	dBm	
TEC Current	-	1	2	A	
TEC Voltage	-	-	2.5	V	
Thermistor resistance		10		k $\Omega$	
Optical Isolation		30			No-isolator option available
Polarization Extinction ratio	17	19	-	dB	PM default, aligned to slow axis. Single mode fiber also available upon request.

## Directly Modulated Laser

Physical Specifications – Butterfly Package	Min.	Typ.	Max.	Unit	Notes
Optical Package		7-pin Butterfly			See mechanical drawings below.
Power Consumption		2	4	W	
Storage Temperature	-20		+70	°C	
Optical Output Connector		FC/APC PM			Other specify upon ordering
Fibre bend radius	30	-	-	mm	
RF Input Connector		2.92 mm (K)			Female
Physical Specifications – LYRA Driver Module					
Dimensions		190 x 110 x 11		mm	
Power Consumption			10	W	
AC Voltage	100		240	V	
DC Supply Voltage	10	12	13	V	AC-DC power supply is provided
Storage Temperature	-20		+70	°C	
Optical Output Connector		FC/APC PM			Other specify upon ordering

### Optical Butterfly Package

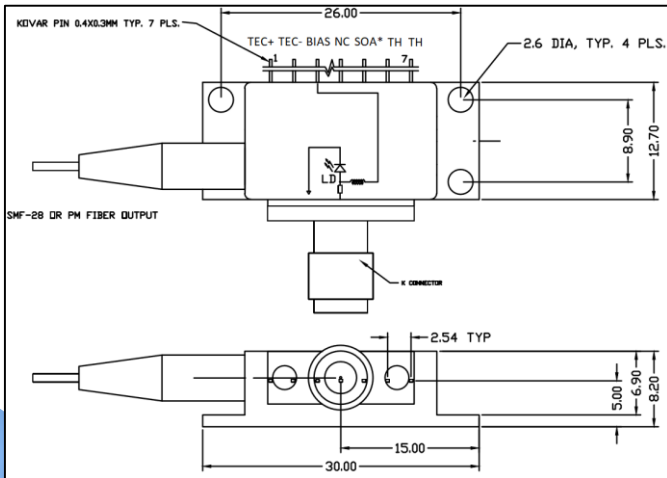

Pin-out is subject to change.

Pin	Description	Pin	Description
1	TEC +	5	SOA when applies
2	TEC -	6	Thermistor
3	Laser anode - Bias	7	Thermistor
4	Not Connected	Shield	Laser cathode

### LYRA Driver

