

DFB-C-PM-M

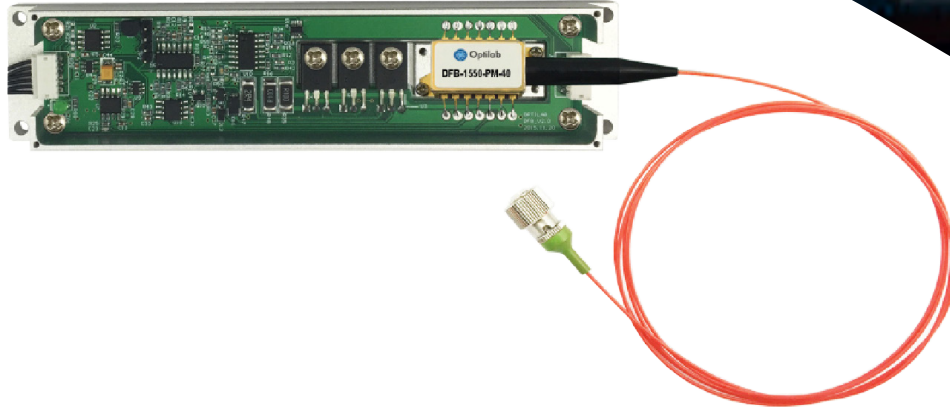

DFB Laser Module, Designed for Use with CMB

The Optilab DFB-C-P-M is a Distributed Feedback (DFB) Polarization Maintaining (PM) laser source module designed to work with Optilab Compact Modulator w/ Bias Control (CMB) for RFoF applications. The DFB-C-P-M can be ordered from more than 20 wavelengths in 1310 nm and 1550 nm ranges. The DFB laser's operating temperature and output power are precisely controlled to ensure constant wavelength stability and power stability. Using its USB interface, the user can control the laser drive current and wavelength via PC interface. Contact Optilab for more information.

Features

- Designed for CMB series
- Polarization Maintaining (PM) output
- Laser linewidth <1 MHz is available
- Built in heat sink
- Up to 40 mW output
- Wavelength tuning range: ± 1 nm
- Over 20 wavelengths available
- USB interface remote control

Applications

- Light source 40G RFoF analog link
- External modulated DWDM networks
- Laboratory testing and measurement
- DFB laser testing
- Interface to CMB for integration

Functional Diagram

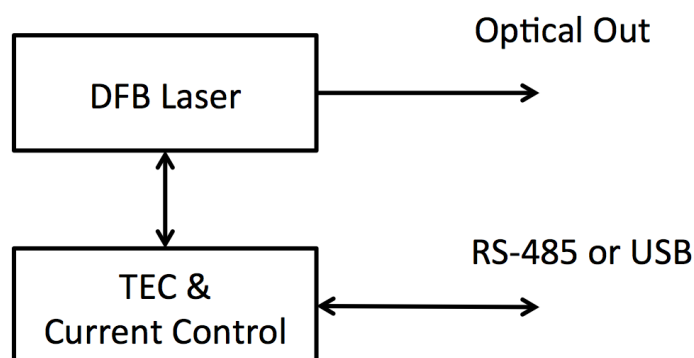

Compact DFB Laser Module, Polarization Maintaining

OPTIONS

DFB-C-PM-M-xxxx-yy
 xxxx Wavelength
 yy Output power (mW)

TECHNICAL INFO

For technical info and support:

sales@optilab.com

www.optilab.com

Technical Specifications	
Available Wavelength Range	O-band: 1270-1350 nm C-band: 1528-1564 nm See attached Table 1.0
Wavelength Accuracy	±50 pm max.
Output Power Level	10 mW, 20 mW, 30 mW, 40 mW
Output Power Stability	±0.2 dB over 8 hours
Wavelength Accuracy	±10 pm over 8 Hours
Laser Linewidth	2 MHz typ., < 1 MHz is available
Side Mode Suppression Ratio	45 dB typ.
Optical Isolation	30 dB typ.
Relative Intensity Noise (RIN)	-140 dB/Hz typ.; -145 dB/Hz is available
Polarization Extinction Ratio	20 dB typ.
Adjustable Features and Output	
DFB Power Output	10 -100% adjustable range
DFB Wavelength Tuning (optional)	±1.0 nm (from wavelength center)

WEB ORDER

To order, please visit OEQuest.com.



Optilab Advantage

- Innovation
- Performance
- Quality
- Customization
- Warranty

Mechanical Specifications	
Operating Temperature	10 °C to +50 °C
Operating Temperature (TQ Version)	-55 °C to +70 °C
Storage Temperature	-65 °C to +85 °C
Operating Humidity	0% to 85% Relative Humidity
Power Supply	± 5 V DC, 500 mA
Power Consumption	5 W max.
Dimensions	145 x 32.5 x 18 mm
Control / Monitoring	LD Current, Laser Wavelength
Remote Control	RS-485 or USB
Optical Connectors	FC/APC; Other options are available
Optical Fiber Type	PANDA for PM Output
Accessories included	USB cable, USB power supply

Application Example of DFB-C-PM-M for RFoF system

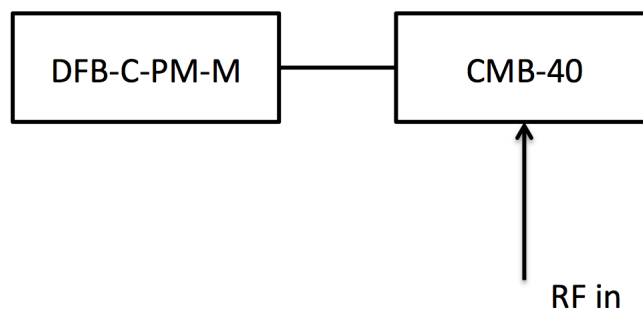

Compact DFB Laser Module, Polarization Maintaining

Mechanical Drawing

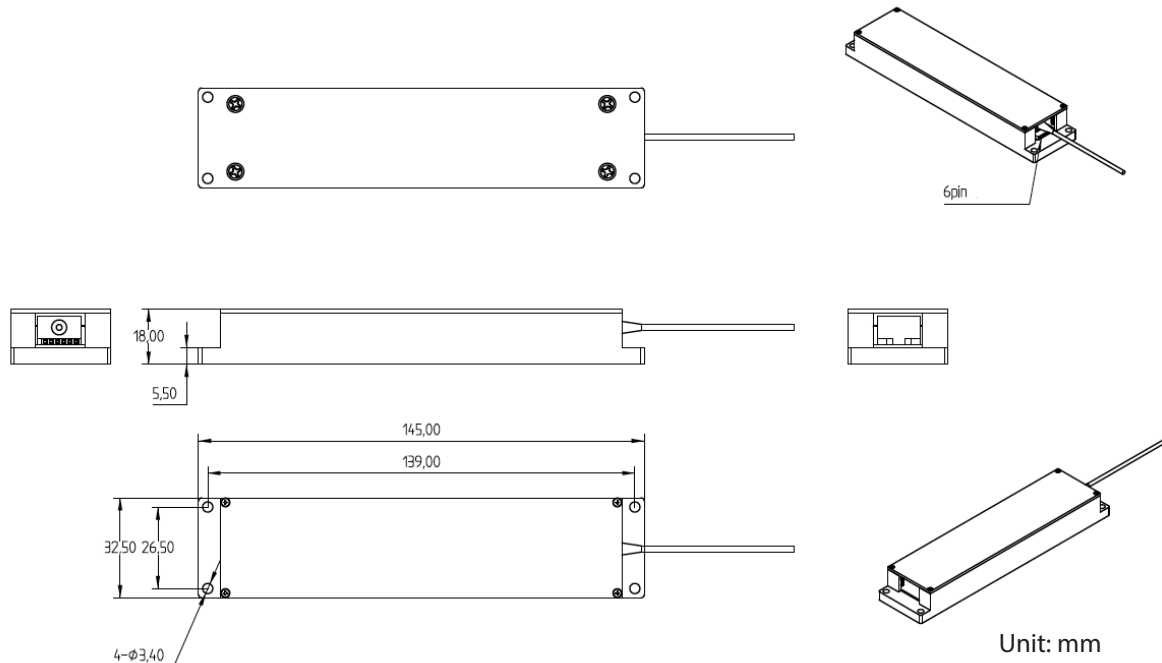

Table 1.0 Available DFB-PM Wavelengths for C-band

Wavelength	
1528 nm	1546 nm
1530 nm	1548 nm
1532 nm	1550 nm
1534 nm	1552 nm
1536 nm	1554 nm
1538 nm	1556 nm
1540 nm	1558 nm
1542 nm	1560 nm
1544 nm	1562 nm

*Other wavelengths are available upon request.